

Physics
Standard level
Paper 1

Thursday 10 May 2018 (afternoon)

45 minutes

Instructions to candidates

- Do not open this examination paper until instructed to do so.
- Answer all the questions.
- For each question, choose the answer you consider to be the best and indicate your choice on the answer sheet provided.
- A clean copy of the **physics data booklet** is required for this paper.
- The maximum mark for this examination paper is **[30 marks]**.

1. A student measures the radius r of a sphere with an absolute uncertainty Δr . What is the fractional uncertainty in the volume of the sphere?

A. $\left(\frac{\Delta r}{r}\right)^3$

B. $3\frac{\Delta r}{r}$

C. $4\pi\frac{\Delta r}{r}$

D. $4\pi\left(\frac{\Delta r}{r}\right)^3$

$\frac{\Delta r}{r} \times 3$

$\frac{4}{3}\pi r^3$

2. A river flows north. A boat crosses the river so that it only moves in the direction east of its starting point.

What is the direction in which the boat must be steered?

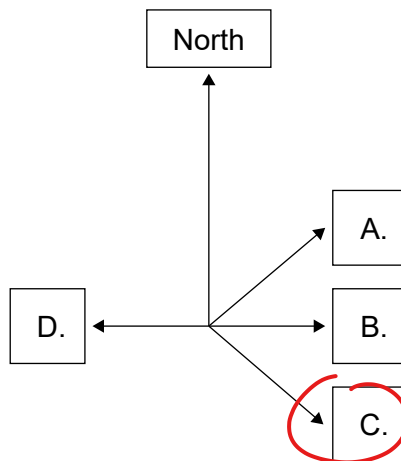

3. An object is projected vertically upwards at time $t = 0$. Air resistance is negligible. The object passes the same point above its starting position at times 2s and 8s.

If $g = 10 \text{ ms}^{-2}$, what is the initial speed of the object?

A. 50

B. 30

C. 25

D. 4



$s = x$
 $u =$
 $v = 0 \text{ ms}^{-1}$
 $a = -10 \text{ ms}^{-2}$
 $t = 5 \text{ s}$

$v = u + at$
 $0 = u + (-10 \times 5)$
 $50 \text{ ms}^{-1} = u$

4. A uniform ladder resting in equilibrium on rough ground leans against a smooth wall. Which diagram correctly shows the forces acting on the ladder?

A.

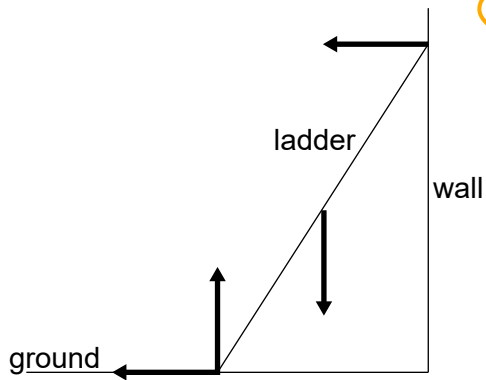

B.

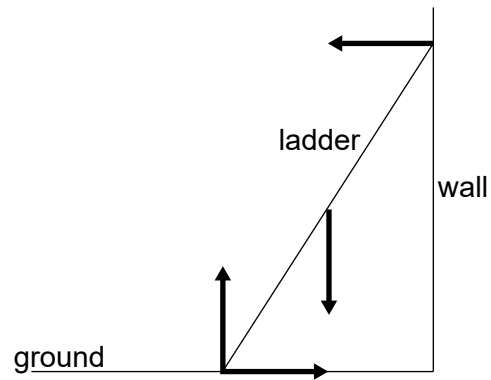

C.

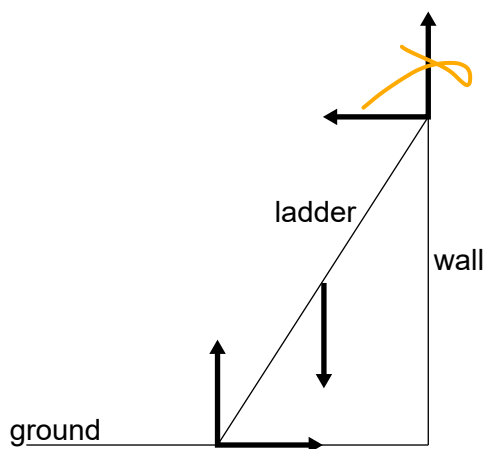

D.

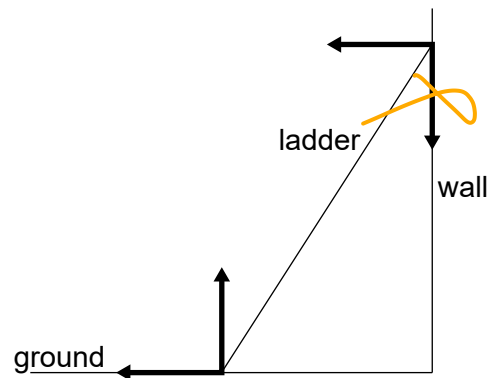

5. An object falls from rest from a height h close to the surface of the Moon. The Moon has no atmosphere.

When the object has fallen to height $\frac{h}{4}$ above the surface, what is

kinetic energy of the object at $\frac{h}{4}$?

 gravitational potential energy of the object at h

- A. $\frac{3}{4}$
- B. $\frac{4}{3}$
- C. $\frac{9}{16}$
- D. $\frac{16}{9}$

$$\frac{\cancel{\frac{3}{4} mgh}}{\cancel{mgh}}$$

6. Child X throws a ball to child Y. The system consists of the ball, the children and the Earth. What is true for the system when the ball has been caught by Y?

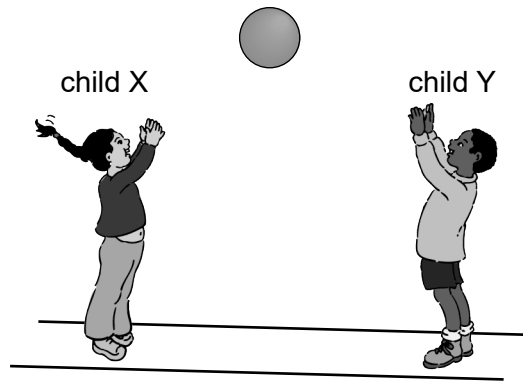

[Source: <https://pixabay.com/en/playing-ball-kids-boy-girl-31339/>]

- A. The momentum of child Y is equal and opposite to the momentum of child X.
 - B. The speed of rotation of the Earth will have changed.
 - C. The ball has no net momentum while it is in the air.
 - D. The total momentum of the system has not changed.**
7. An increasing force acts on a metal wire and the wire extends from an initial length l_0 to a new length l . The graph shows the variation of force with length for the wire. The energy required to extend the wire from l_0 to l is E .

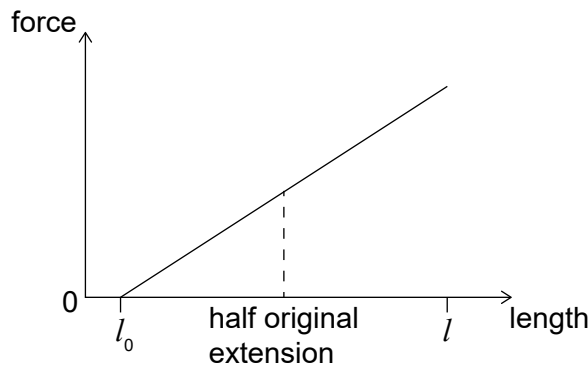

The wire then contracts to half its original extension.

What is the work done by the wire as it contracts?

- A. $0.25E$
- B. $0.50E$
- C. $0.75E$**
- D. E

$\frac{3}{4}$ of E needed to go back

$$E = \frac{1}{2}k\Delta x^2$$

$$E = \frac{1}{2}k\left(\frac{1}{2}x\right)^2$$

$$E = \frac{1}{2}k\frac{1}{4}x^2$$

8. The distances between successive positions of a moving car, measured at equal time intervals, are shown.

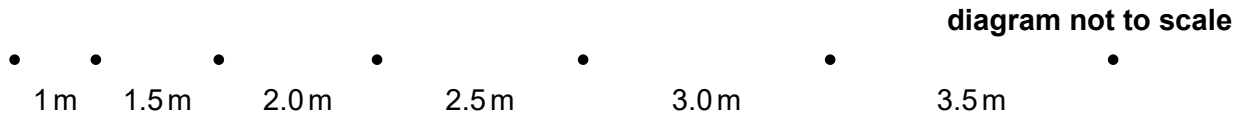

The car moves with

- A. acceleration that increases linearly with time.
 - B. acceleration that increases non-linearly with time.
 - C. constant speed.
 - D. constant acceleration.
9. An object is moving in a straight line. A force F and a resistive force f act on the object along the straight line.

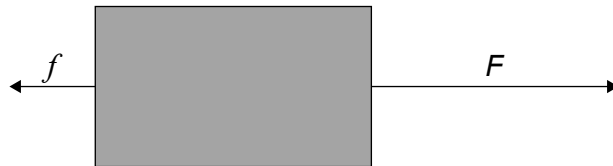

Both forces act for a time t .

What is the rate of change of momentum with time of the object during time t ?

- A. $F + f$
- B. $F - f$
- C. $(F + f)t$
- D. $(F - f)t$

$$F - f = F_{\text{NET}}$$

$$\frac{\Delta p}{\Delta t} = \frac{F \Delta t}{\Delta t}$$

$$\frac{\Delta p}{\Delta t} = F_{\text{NET}} = F - f$$

10. A fixed mass of an ideal gas is trapped in a cylinder of constant volume and its temperature is varied. Which graph shows the variation of the pressure of the gas with temperature in degrees Celsius?

$PV = nRT$
 $P \propto T$

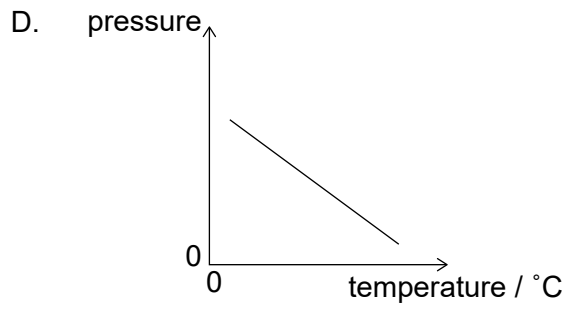
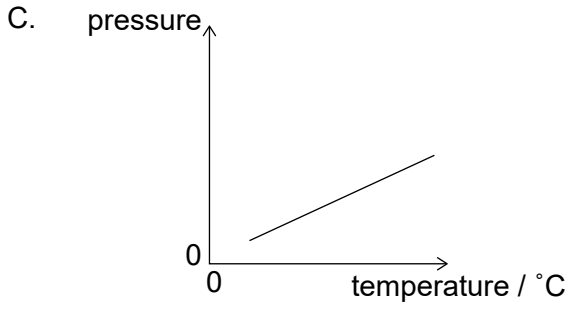
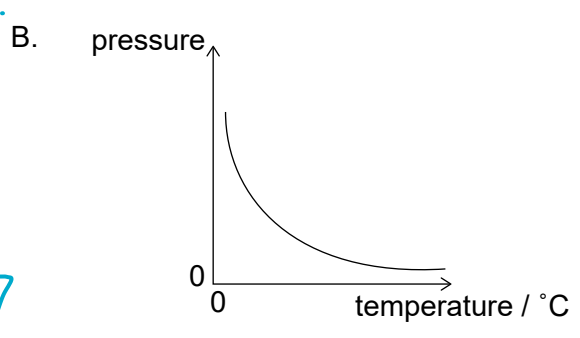
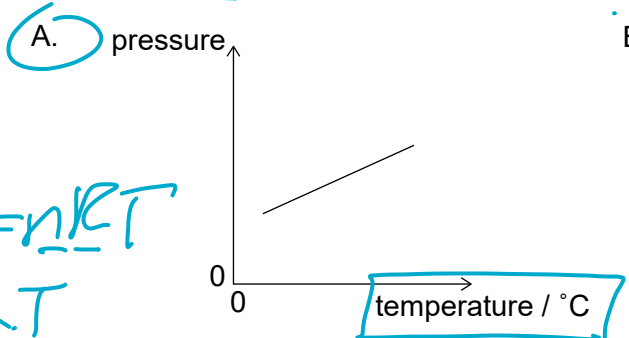

11. What are the units of the ratio $\frac{\text{specific heat capacity of copper}}{\text{specific latent heat of vaporization of copper}}$?

- A. no units
- B. k
- C. k^{-1}
- D. k^{-2}

$Q = mc\Delta T$
 $\frac{Q}{m\Delta T} = c_{\text{copper}}$

$\frac{Q}{m\Delta T} \therefore \frac{Q}{m}$
 $\frac{Q}{m\Delta T} \times \frac{m}{Q} = \frac{1}{T}$ in Kelvin
 $Q_{\text{copper}} = mL$
 $\frac{Q_{\text{copper}}}{m} = L$

12. A sealed cylinder of length l and cross-sectional area A contains N molecules of an ideal gas at kelvin temperature T .

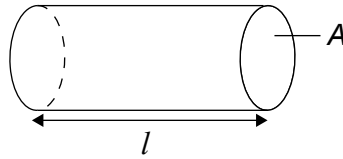

What is the force acting on the area of the cylinder marked A due to the gas?

A. $\frac{NRT}{l}$

B. $\frac{NRT}{lA}$

C. $\frac{Nk_B T}{lA}$

D. $\frac{Nk_B T}{l}$

Handwritten work:

$$p = \frac{F}{A} =$$

$$\frac{nRT}{V} = \frac{F}{A}$$

$$\frac{AnRT}{V} = F$$

$$nR = Nk_B$$

$$F = \frac{nRT}{L} = \frac{Nk_B T}{L}$$

$$pV = nRT$$

$$p = \frac{nRT}{V}$$

13. A first-harmonic standing wave is formed on a vertical string of length 3.0m using a vibration generator. The boundary conditions for this string are that it is fixed at one boundary and free at the other boundary.

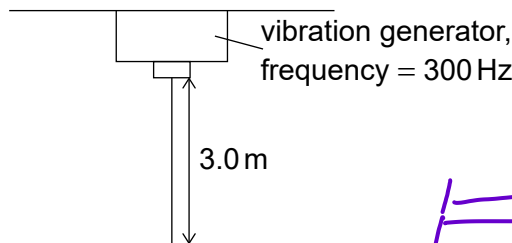

diagram not to scale

The generator vibrates at a frequency of 300 Hz.

What is the speed of the wave on the string?

- A. 0.90 kms⁻¹
- B. 1.2 kms⁻¹
- C. 1.8 kms⁻¹
- D. 3.6 kms⁻¹**

Handwritten work:

$$f_1 : \lambda = 4L$$

$$\lambda = 4 \times 3 = 12m$$

$$v = f \lambda$$

$$= 300 \times 12$$

$$= 3600m s^{-1}$$

14. Two travelling waves are moving through a medium. The diagram shows, for a point in the medium, the variation with time t of the displacement d of each of the waves.

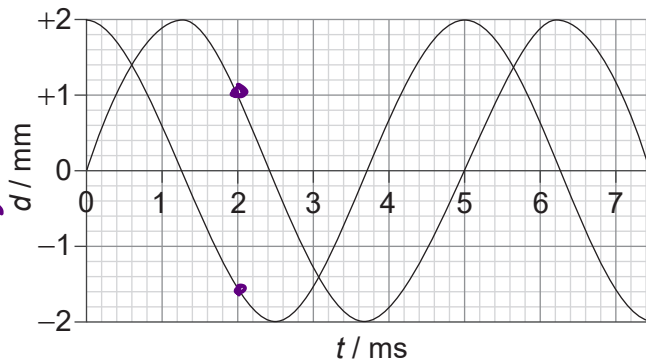

$T = 5 \text{ seconds}$
 difference is 1.2 seconds
 about $\frac{1}{4}$ of λ
 $360 \times \frac{1}{4} = 90^\circ$

For the instant when $t = 2.0 \text{ ms}$, what is the phase difference between the waves and what is the resultant displacement of the waves?

	Phase difference	Resultant displacement / mm
A.	45°	-0.6
B.	90°	2.6
C.	45°	2.6
D.	90°	-0.6

15. The diagram shows an interference pattern produced by two sources that oscillate on the surface of a liquid.

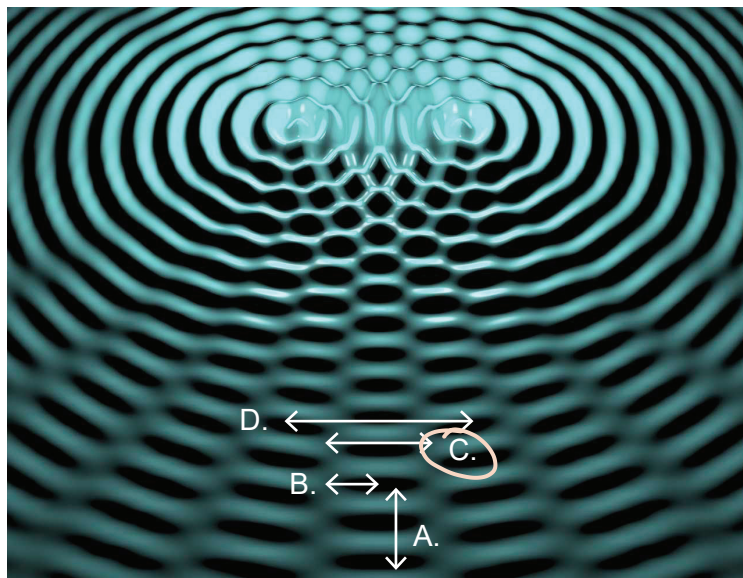

[Source: Science Photo Library www.sciencephoto.com]

Which of the distances shown in the diagram corresponds to one fringe width of the interference pattern?

16. A system that is subject to a restoring force oscillates about an equilibrium position.

For the motion to be simple harmonic, the restoring force must be proportional to

- A. the amplitude of the oscillation.
- B.** the displacement from the equilibrium position.
- C. the potential energy of the system.
- D. the period of the oscillation.

SHM

17. A particle is displaced from rest and released at time $t = 0$. It performs simple harmonic motion (SHM). Which graph shows the variation with time of the kinetic energy E_k of the particle?

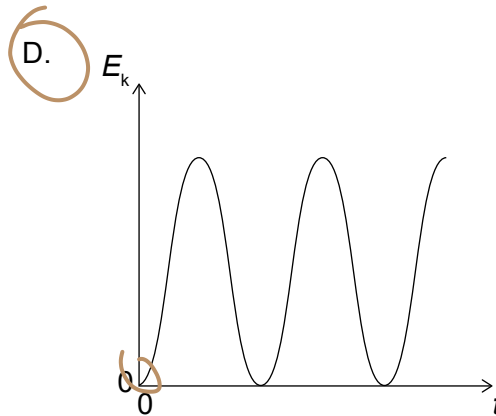
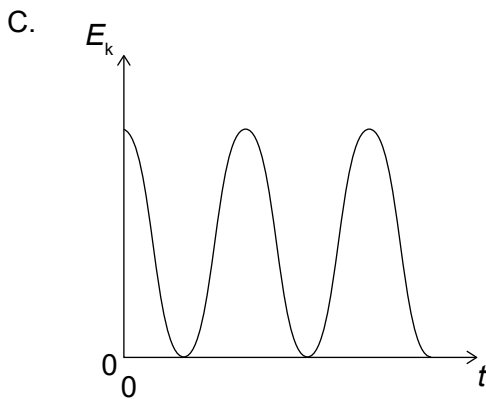
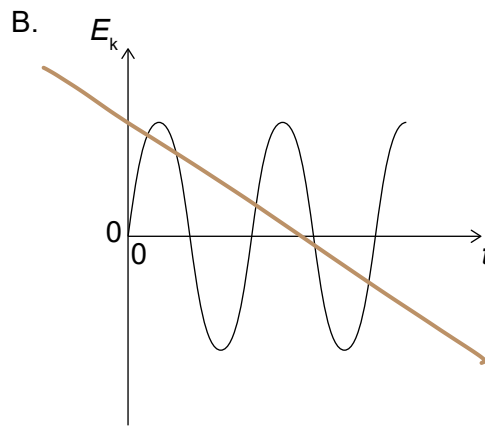
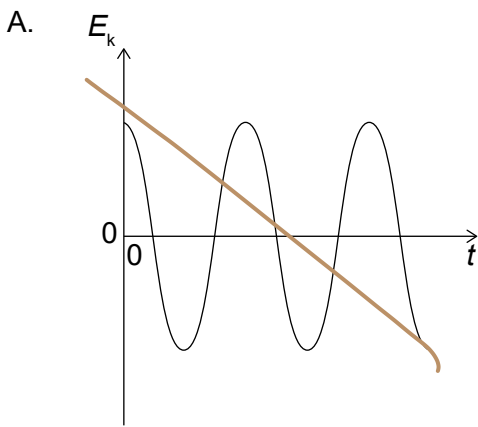

18. Three resistors are connected as shown. What is the value of the total resistance between X and Y?

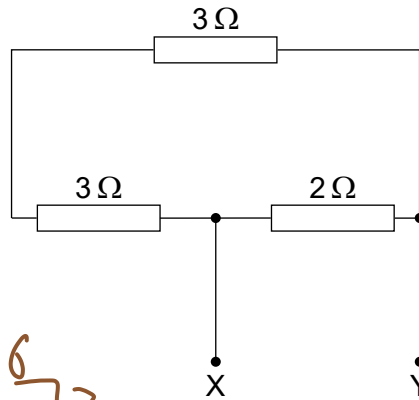

- A. 1.5Ω
- B. 1.9Ω
- C. 6.0Ω
- D. 8.0Ω

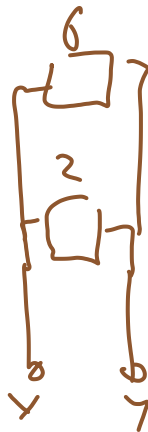

$$\frac{1}{6} + \frac{1}{2} = \frac{1}{R_T}$$

$$\frac{4}{6} = \frac{1}{R_T}$$

$$R_T = \frac{3}{2} = 1.5$$

19. A liquid that contains negative charge carriers is flowing through a square pipe with sides A, B, C and D. A magnetic field acts in the direction shown across the pipe.

On which side of the pipe does negative charge accumulate?

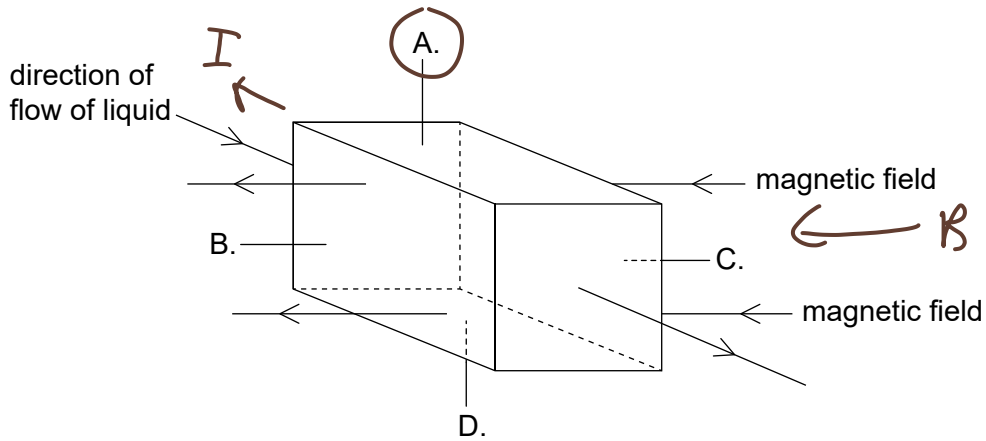

20. Five resistors of equal resistance are connected to a cell as shown.

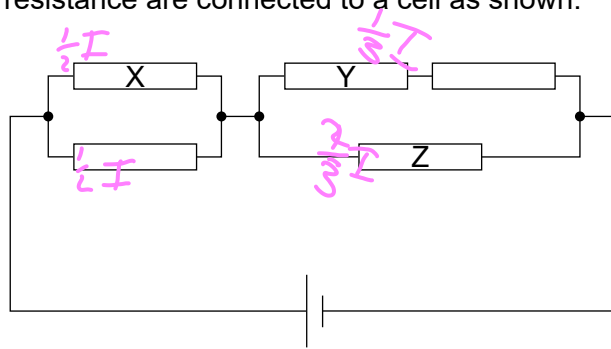

What is correct about the power dissipated in the resistors?

- A. The power dissipated is greatest in resistor X.
- B. The power dissipated is greatest in resistor Y.
- C. The power dissipated is greatest in resistor Z.
- D. The power dissipated is the same in all resistors.

most current through Z

21. Two resistors X and Y are made of uniform cylinders of the same material. X and Y are connected in series. X and Y are of equal length and the diameter of Y is twice the diameter of X.

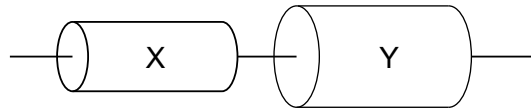

The resistance of Y is R .

What is the resistance of this series combination?

- A. $\frac{5R}{4}$
- B. $\frac{3R}{2}$
- C. $3R$
- D. $5R$

Handwritten work:

$$p = \frac{RA}{L}$$

$$\frac{pL}{A} = R$$

$$R \propto \frac{1}{A}$$

$$R \propto \frac{1}{r^2}$$

$$R_Y = \frac{1}{4} R_X$$

$$4R_Y = R_X$$

$$4R = R_X$$

$$R = R_Y$$

22. An object of mass m at the end of a string of length r moves in a vertical circle at a constant angular speed ω .

What is the tension in the string when the object is at the bottom of the circle?

- A. $m(\omega^2 r + g)$
- B. $m(\omega^2 r - g)$
- C. $mg(\omega^2 r + 1)$
- D. $mg(\omega^2 r - 1)$

$$F_c = T - mg$$
$$F_c + mg = T$$
$$m\omega^2 r + mg = T$$
$$m(\omega^2 r + g)$$

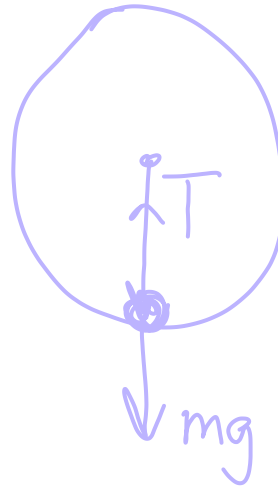

23. Newton's law of gravitation

- ~~A.~~ is equivalent to Newton's second law of motion.
- ~~B.~~ explains the origin of gravitation.
- C. is used to make predictions.
- ~~D.~~ is not valid in a vacuum.

24. Which Feynman diagram shows beta-plus (β^+) decay?

- A.
- B.
- C.
- D.

25. The average binding energy per nucleon of the $^{15}_8\text{O}$ nucleus is 7.5 MeV. What is the total energy required to separate the nucleons of one nucleus of $^{15}_8\text{O}$?

- A. 53 MeV
- B. 60 MeV
- C. 113 MeV**
- D. 173 MeV

$15 \times 7.5 \text{ MeV} =$

26. Two pure samples of radioactive nuclides X and Y have the same initial number of atoms. The half-life of X is $T_{\frac{1}{2}}$.

After a time equal to 4 half-lives of X the ratio $\frac{\text{number of atoms of X}}{\text{number of atoms of Y}}$ is $\frac{1}{8}$.

What is the half-life of Y?

$100 \rightarrow 50 \rightarrow 25 \rightarrow 12.5 \rightarrow 6.25$

- A. $0.25T_{\frac{1}{2}}$
- B. $0.5T_{\frac{1}{2}}$
- C. $3T_{\frac{1}{2}}$
- D. $4T_{\frac{1}{2}}$**

$1:8$
 $6.25:50$
 $\times 6.25$
1 half life in 4 half lives

27. The energy-level diagram for an atom that has four energy states is shown.

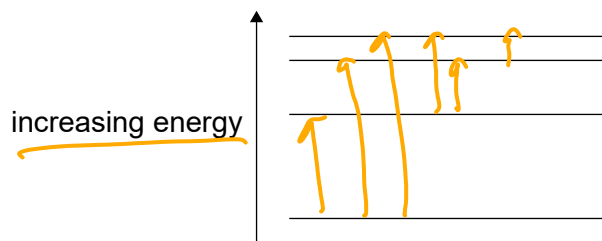

What is the number of different wavelengths in the emission spectrum of this atom?

- A. 1
- B. 3
- C. 6**
- D. 7

28. What is equivalent to $\frac{\text{specific energy of a fuel}}{\text{energy density of a fuel}}$?

A. density of the fuel

B. $\frac{1}{\text{density of the fuel}}$

C. $\frac{\text{energy stored in the fuel}}{\text{density of the fuel}}$

D. $\frac{\text{density of the fuel}}{\text{energy stored in the fuel}}$

$$\frac{\text{J kg}^{-1}}{\text{J m}^{-3}} = \frac{\text{J m}^3}{\text{J kg}} = \frac{\text{m}^3}{\text{kg}} = \frac{1}{\text{density}}$$

29. Three energy sources for power stations are

- I. fossil fuel ✓
- II. pumped water storage ✓
- III. nuclear fuel. ✓

Which energy sources are primary sources?

A. I and II only

B. I and III only

C. II and III only

D. I, II and III

30. The diagram shows a simple climate model for the Earth.

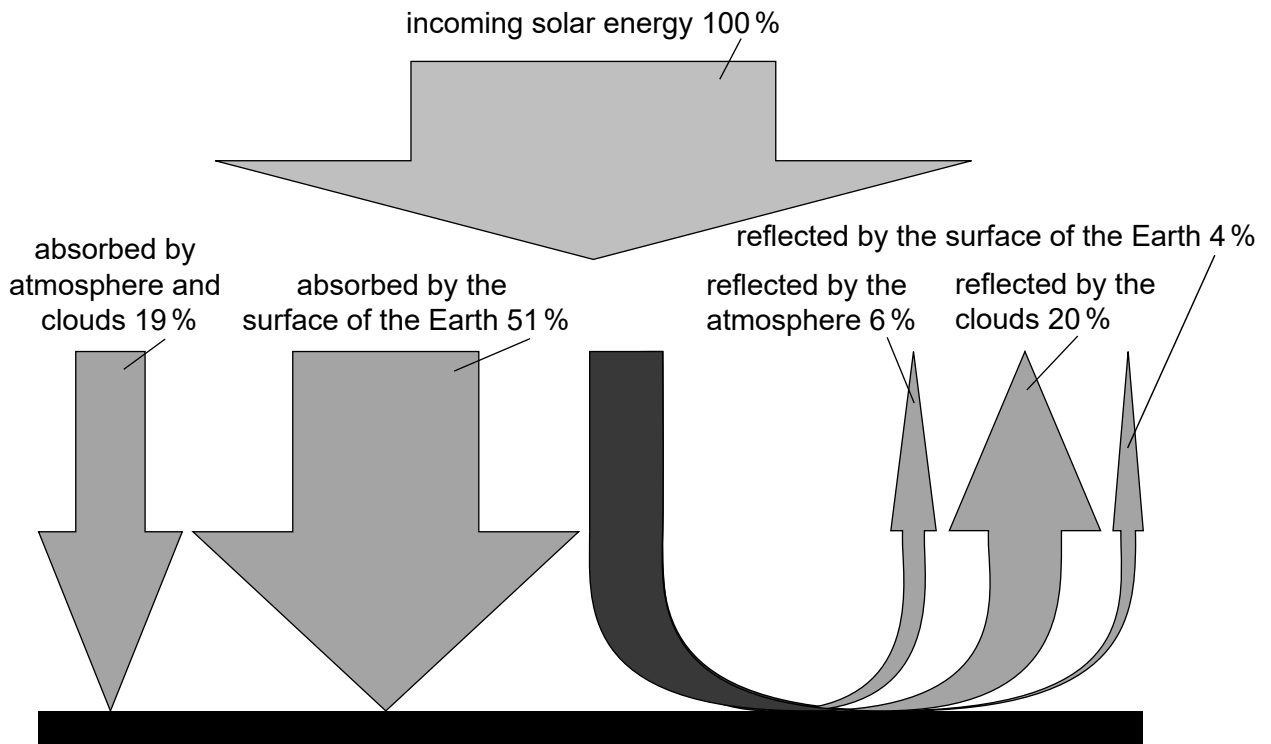

What does this model predict for the average albedo of the Earth?

- A. 0.30
- B. 0.51
- C. 0.70
- D. 0.81

$$\frac{6 + 4 + 20}{100} = 0.3 = 30\%$$